



TECHNOLOGY FOR CLEAN PRODUCTION

Operating Instructions

DUSTCONTROL Dust Extractor for Folding Equipment

S 3800 TED 30 – 2.5 kW

I . S 3800 Dust separator

I. 1 Technical data

I. 2 Accessories

I. 3 Functional description

I. 4 Test run

I. 5 Error diagnostics

I. 6 Guarantee

I. 7 Maintenance

I. 8 Safety regulations

I. 9 Replacement parts

I. 10 Consumables

II. TED 30 – 2.5 kW Turbo pump

II. 1 Technical data

II. 2 Functional description

II. 3 Installation

II. 4 Maintenance

II. 5 Test run

II. 6 Guarantee

II. 7 Safety regulations

II. 8 Error diagnostics

II. 9 Replacement parts

Appendix 1: Maintenance and set-up of the vacuum valve



General functional description

The DUSTCONTROL Folding Equipment dust extractor, has been designed for direct dust extraction at the cutting blades, as well as for general cleaning purposes.

Dust is either collected on the special collection elements at the blades or through cleaning connectors (flap valves) that have extraction hoses with cleaning jets connected to them.

The fine dust is separated in the S 3800 dust separator in 2 stages:

Stage 1 is cyclonic separation using centrifugal force

Stage 2 is an 1.8 m² large fine filter cartridge with a separation ratio of 99.9 %.

The micro dust is separated in the downstream micro-filter with a 99.995% separation ratio, at the end of the expulsion ducting.

The required vacuum is created by a TED 30 or 36 Turbo Pump, operating according to the by-pass channel principle. This is located on the clean-air side, after the dust separator.

If all connectors are closed, the cool air required for the by-pass channel compressor is controlled through a vacuum valve (see Appendix 1 for settings), on the extraction side of the pump.

I. S 3800 Dust separator

I. 1 Technical data

Inlet \varnothing 50 mm
 Outlet \varnothing 50 mm

Filter surface
 Fine filter, Part No. 4292 1.8 m²

Separation ratio 99.9%
 in accordance with DIN 24184 /3
 Maximum temperature 130°C

Filter cleaning is done through air pulsing
 Compressed air 4 l/s, 4 bar

Pneumatic control signal

Maximum air quantity 350 m³/h
 Please take note of the load being placed on the filter

Pressure drop

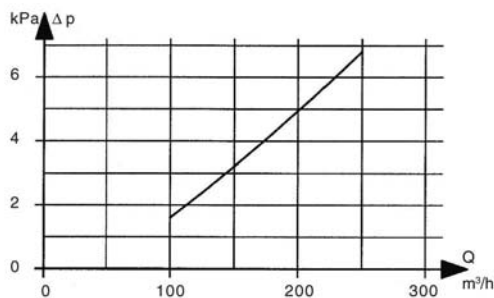

An additional micro-filter in the
 expulsion duct, Part No. 4366 1.2 m²
 Separation ratio (in accordance with DOP) 99.995 %
 Maximum temperature 80 °C



I. 2 Accessories

Description	Part no.
Dust bag	F30031
Category "C" fine filter	42025
Category "K1" micro-filter	4366

Please refer to our DUSTCONTROL Catalogue for further accessories.

I. 3 Functional description

Thanks to its modular design, the S 3800 can be put together in several ways. This has the advantage that the inlet can be turned and positioned in such a way that the dust separator can be customised to the local conditions, without any problem.

With the S 3800, the filter is cleaned by an automatic control signal, which sends a pulse of air against the direction that the dust is being extracted in. This is a very effective form of cleaning while at the same time protecting the filter.

The dust is separated into a plastic bag in a 40l-container located under the cyclone. Needless to say, there are other dust removal solutions, which you can find in the DUSTCONTROL Catalogue.

I. 4 Test run

1. Make sure that the vacuum generator is correctly installed.
2. Ensure that the inlet and outlet are connected to the ducting system.
3. The ducting between the dust separator and the vacuum generator must be completely free of any particles. Rivets or other similar objects that are sucked into the vacuum generator can cause major damage.
4. Check to make sure that the removal cone is fixed correctly, so that no air can be sucked from there.
5. Switch on the equipment.
6. While the filter is being cleaned out, several clearly audible pulses of air can be heard every 15 seconds or so.



I. 5 Error diagnosis

Filter cleaning is not working.

Note: The filter is only cleaned once the vacuum generator has come to a stop and a defined timeout has elapsed.

- Pneumatic control signal is not present. Compressed air feed is interrupted. Check the membrane valve, ducting, hoses and compressed air supply.

The vacuum generator is running, but there is no suction effect in the system.

- Ducting and/or hoses are blocked. Clean them.
- No container has been installed at the dust separator to collect the dust. Install a plastic bag or a container. The vacuum generator is turning in the wrong direction. Get an electrician to reverse the rotation direction.

The vacuum generator is running, but the suction effect in the system is poor.

- There is a leak in the ducting or there are foreign bodies in the ducts.
- Defective hoses.
- Filter blocked. Clean or exchange filter.

I. 6 Guarantee

The guarantee runs for 12 months if the machinery is used in single-shift operation. The length reduces pro-rata in multi-shift operation.

The guarantee is only valid if the dust separator has been maintained according to the defined schedule and only if the equipment is used for the purpose for which it was designed, as well in the case of any manufacturing faults.

Repairs may only be carried out by DUSTCONTROL or by someone authorised by DUSTCONTROL to carry out such repairs. If this is not done, no claims may be made under the terms of the guarantee.



I. 7 Maintenance

As substances that can be injurious to health may be separated by the S 3800 must be overhauled at least once a year and thoroughly checked for correct functioning.

It is important to replace the filter once it can no longer be cleaned effectively. How often a filter needs to be exchanged depends very much on the dust content and on how much air is extracted. However, the filters must be exchanged at least once a year..

You can check how blocked the filter is by measuring the pressure loss above the dust separator with a pressure gauge, part no. 8283. Compare the result with the graph shown under "Technical data". If the measured value is above that shown in the graph, the filter should be exchanged.

Some while after installation, you should re-tighten all screws and nuts.

Changing the dust collector

The plastic bag should only be changed after the filter has been cleaned. The plastic bag (part no.: F30031) must be changed if the dust reaches a level approx. 5 cm below the container edge.

Before you start to empty or change the bag, the extraction equipment must be turned off at the switching cabinet and at the main switch and it should be secured against accidentally being switched back on.

If the equipment has a disposal container, once the equipment has been switched off and secured as described above, the bag is removed from the cyclone by opening the tenterhooks. A new plastic bag has to be placed into the container and pulled over the edge and secured with the tenterhooks at the cyclone.

The extraction equipment may be turned back on again, once the container has been emptied or changed.

Note:

The separated material must be disposed of correctly and in line with the corresponding regulations and guidelines.



Changing the filter

You should only use original DUSTCONTROL filter cartridges: S 3800 filter cyclone fine filters, part no.: 42025; micro-filter for the end of the expulsion ducting, part. no.: 4366.

You should observe the following procedures with the fine filter 42025:

1. Check that the filter cleaning is working and operate it several times, to blow out any loose dust.
2. The extraction equipment must be switched off and secured against accidentally being switched on again.
3. Open the tenterhooks on the cover and take the cover off.

Please note: Protective clothing must be worn while carrying out this work.

4. Carefully pull the filter cartridge up to remove it and dispose of it an environmentally-aware way.
5. Feed in a new DUSTCONTROL Filter cartridge (Part No. 42025) vertically from above. Make sure that the filter material is not damaged by this procedure.

Please note: You must ensure that the gasket is correctly positioned and is not pinched.

6. Lay the cover on the cyclone and close the tenterhooks.
7. Switch on the equipment and carry out a test run. Check the extraction ducting to make sure that no dust is escaping. If dust is to be extracted over a longer period of time, switch the equipment off and secure it.
8. Remove the cover (see Point 3) and check that the filter is correctly positioned (Point 5).
9. Check the filter plate for any traces of dust.
10. Put everything back together and carry out a test run, as described above. If dust should still continue to escape from the exhaust duct, in the absence of a downstream micro-filter, please contact your nearest DUSTCONTROL office.



TECHNOLOGY FOR CLEAN PRODUCTION

The micro-filter 4366 is fixed in place with a bayonet fitting.

- Make sure it is inserted correctly
- Tighten it by turning it in a clockwise direction
- Loosen it by turning it in a counter-clockwise direction

Only use original parts when carrying out component changes.

I. 8 Safety regulations

- This unit may only be installed and maintained by authorised and trained personnel.
- The electrical installation work must be carried out by a qualified electrician.
- Never work on the dust separator without first switching off and disabling the vacuum generator operating switch.
- This unit may only be started up if the ducting system is connected.
- Always clean the filter before you remove the container or the plastic bag from the cyclone.
- The equipment must be switched off and secured against accidentally being switched back on again, before removing the plastic bag or the container from the cyclone.
- You must always follow the corresponding guidelines and regulations when handling the separated dust.
- It is strictly forbidden to test the suction power of the equipment, using your hand or any other part of your body.
- The exhaust air can reach temperatures of 150°C. Keep a safe distance.

I. 9 Replacement parts

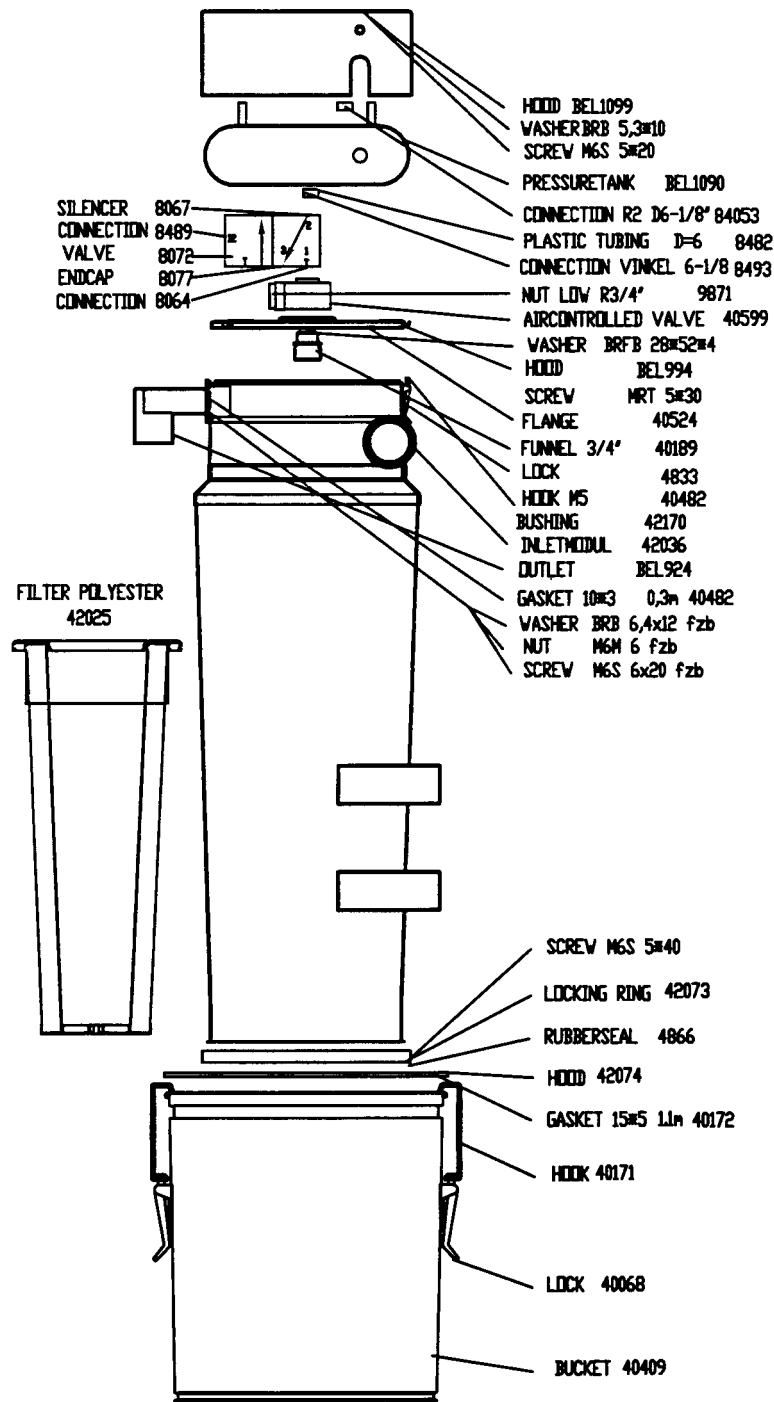



I. 10 Consumables

II. TED 30 – 2.5 kW Turbo pump

II. 1 Technical data

Rev. count	max 3,000 rpm
Weight	30 kg
Suction pressure	max 20 kPa
Air quantity	max 260 m ³ /h
Inlet/Outlet	50mm
Noise level with sound damper	75 dB(A)
Housing sound level 1m	

Pressure generation and performance

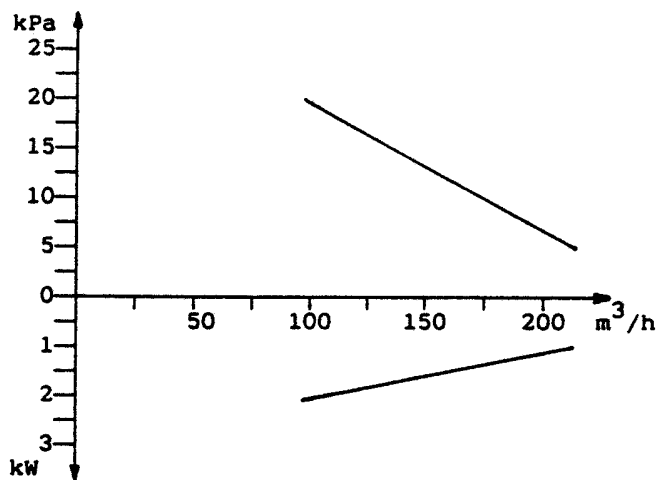

The pump graph is valid for negative pressure. Pressure differences are greater with negative pressure. As a guideline, you can set the positive pressure 40% above the negative pressure.



TECHNOLOGY FOR CLEAN PRODUCTION

Mounting dimensions

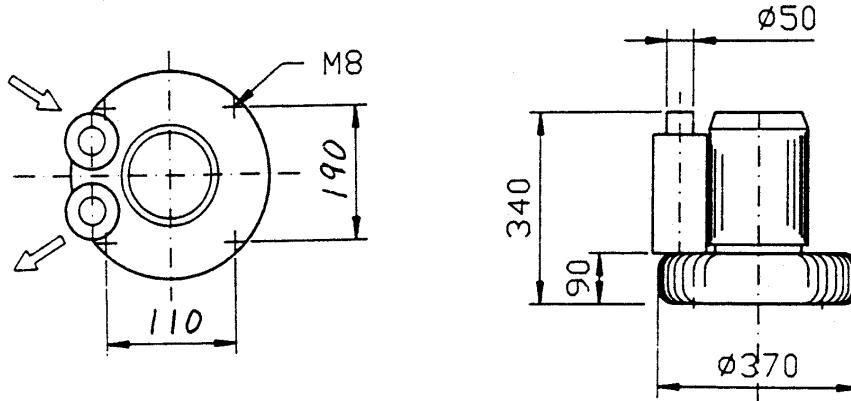

Nominal power

Part no.	V	Hz	Nominal power
4322	380-420	50	2.5 kW
Accessory Console, 500mm, to install the pump on the wall		Part no. 3037	
Vacuum valve		8001	



II. 2 Functional description

By-pass channel compressor

The TED 30 2.5kw turbo pump is a by-pass channel compressor. The rotors run between outlet and inlet through a passage with very little room for play. For this reason it is very important the pump doesn't suck in any particles, because of the danger of damaging the unit. The turbo pump compresses the air and it is perfectly normal for the pump housing to get warm in use.

Direct drive

The pump is driven directly from a 3-phase motor.

Cooling

The cooling air for the pump is normally got through a vacuum valve (part no. 8001), which is mounted on the intake side, directly next to the pump.

II. 3 Installation

1. Screw the pump to the console mounted on the wall or to another secure mounting point.
2. Connect the inlet and outlet. Never start the pump without attaching all ducting.
3. The inlet must always be connected to a dust separator with a filter, so that no particles can find their way into the pump.
4. The outlet can be equipped with a sound damper. The outlet noise level will be reduced by 75 db (A) in this way.
5. If the exhaust opening goes upwards, the pipe must be fitted with a rain cover, using an elbow bend or similar. The exhaust air can reach a temperature of 100-150°C.
6. The electrical installation work may only be carried out by authorised personnel. An operating switch that can be closed off must be installed close to the pump.
7. The switch cabinet must be fitted with a thermal motor protection, which has been installed and tested by authorised personnel. Check that the pump has the correct rotation direction.

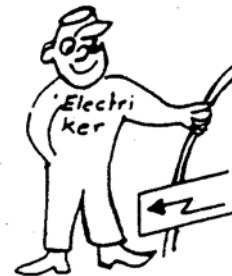
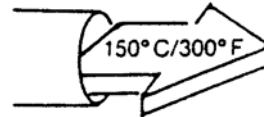

II. 4 Maintenance

The pump is maintenance-free.



II. 5 Test run

1. Switch off and disable the operating switch.
2. Check that the pump can be switched on without problem and that all system outlets are closed.
3. Connect a pressure gauge, calibrated to at least 30 kPa on the suction side and as close to the pump as possible.
4. Switch the operating switch on. Start the pump and listen for any unusual noises. You should be able to hear a higher-pitched tone from the rotor gears. If the pump is sucking air from the vacuum valve, a low hissing is heard.
5. Measure the negative pressure on the intake side and compare the results with the pressure that is calculated for the equipment. The pressure can be modified by adjusting the vacuum valve.
6. Check the function of the extraction system.
7. It is completely normal that the pump outlet gets very hot after an hour of operation.

II. 6 Guarantee

The guarantee runs for 12 months if the machinery is used in single-shift operation. The length reduces pro-rata in multi-shift operation. The guarantee covers manufacturing faults provided that the pump has only be used for the purpose for which it was designed.

Repairs may only be carried out by DUSTCONTROL or by someone authorised by DUSTCONTROL to carry out such repairs. If this is not done, no claims may be made under the terms of the guarantee.

II. 7 Safety regulations

- The equipment may only be installed by authorised personnel who have read and understood these installation and service instructions.
- The electrical installation work must be carried out by a qualified electrician.
- An operating switch that can be closed off must be installed close to the pump.
- PLEASE NOTE – high negative pressure
- The pump may only be started up if the ducting system is connected.
- Never check the negative pressure using your hand or any other part of your body.
- The exhaust air can reach a temperature of 150°C.

II. 8 Error diagnosis

The motor isn't running.

- No power connected. Connect power.
- The motor protection in the switching cabinet has triggered. Motor overloaded.
- No power supply. Check connections and cables.
- Safety switch is switched off. Switch it on.

The motor cuts out immediately after start-up.

- Wrong fuse. Change the fuse.
- Motors protection set too low. have it modified by an electrician.

The motor is running but the machine is not sucking.

- Ducts or hoses blocked. Clean them.
- No container installed at the dust separator. Install a plastic bag or a container.
- The pump is running in the wrong direction. Have the phases changed by an electrician.

The motor is running, but the suction effect in the system is poor.

- There is a hole in the hoses or a leak in the ducting system. Check.
- Filter blocked. Clean or change the filter.

Unusual noises coming from the pump.

- Particles may have found their way into the pump. Switch off and call maintenance.



TECHNOLOGY FOR CLEAN PRODUCTION

II. 9 Replacement parts

Part no.	Description
4304	2.5kW, 400V/50HZ motor
4306	Housing and cover for the fan
4307	Fan gear
4308	Sound damper housing
4311	Spacer
4312	End plate
4323	End cover
4325	Sound damper insert
T001	Radial gasket
T002	Tolerance disk
94999-1197	TED 30 2.5 kW/50 HZ RAL 7036 Turbo pump complete

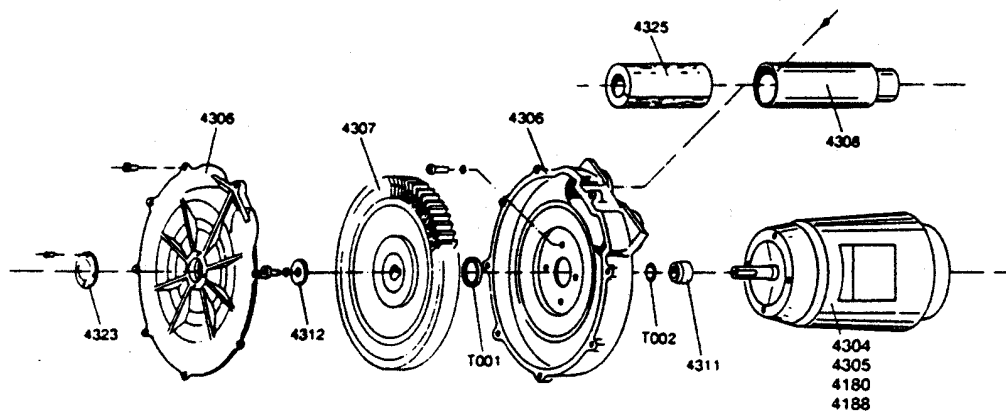

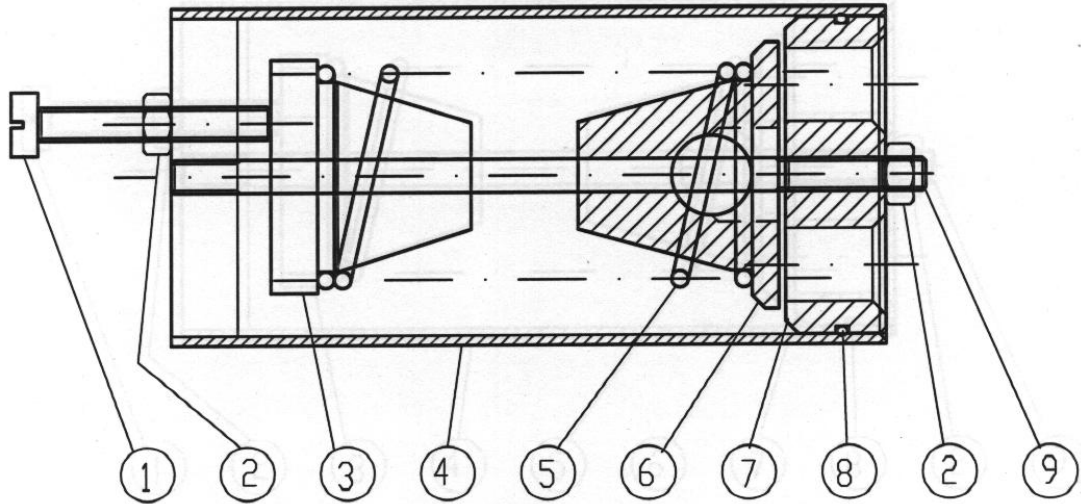

	1	DECAL ARROW	ART.NR: 9518
	1	DECAL DC	ART.NR: 9515
9	1	AXLE	RITN: 6C941989
8	1	O-RING $\phi 45,5 \times 1,5$ NBR70	ART.NR:
7	1	INLETPLATE	RITN: 6C941988
6	1	SEALPLATE	RITN: 6C941984
5	1	SPRING	RITN: 6C941987
4	1	HOUSE	RITN: 6C941986
3	1	SPRINGHOLDER	RITN: 6C941985
2	2	NUT	M5 FZB
1	1	SCREW	MCS 5x35
PDS		ANT/PCS	BENZNING/NAME
TOLERANS DZR E.J ANNAT ANGES:		YTBEHANDLING P? TILLV. DET:	
TOLERANCES IF NOT INDICATED:		SURE.TREATM. ON MAN. PARTS:	
DATUM:		ERSZTTER:	SMST.RITN:
DATE:		REPLACES:	ASS.DWG:
ART.NR:		BENZNING:	
ART.ND:		NAME:	
		VACUUMVALVE $\phi 50$	
		SMST	
Dustcontrol		RITNINGSNR/DRAWINGNO:	SKALA/SCALE:
		6C941990	1:1
		SIGN:	FORMAT:
		MJ	